

Screening Technology With A Visible Difference

TURBO-SCREEN

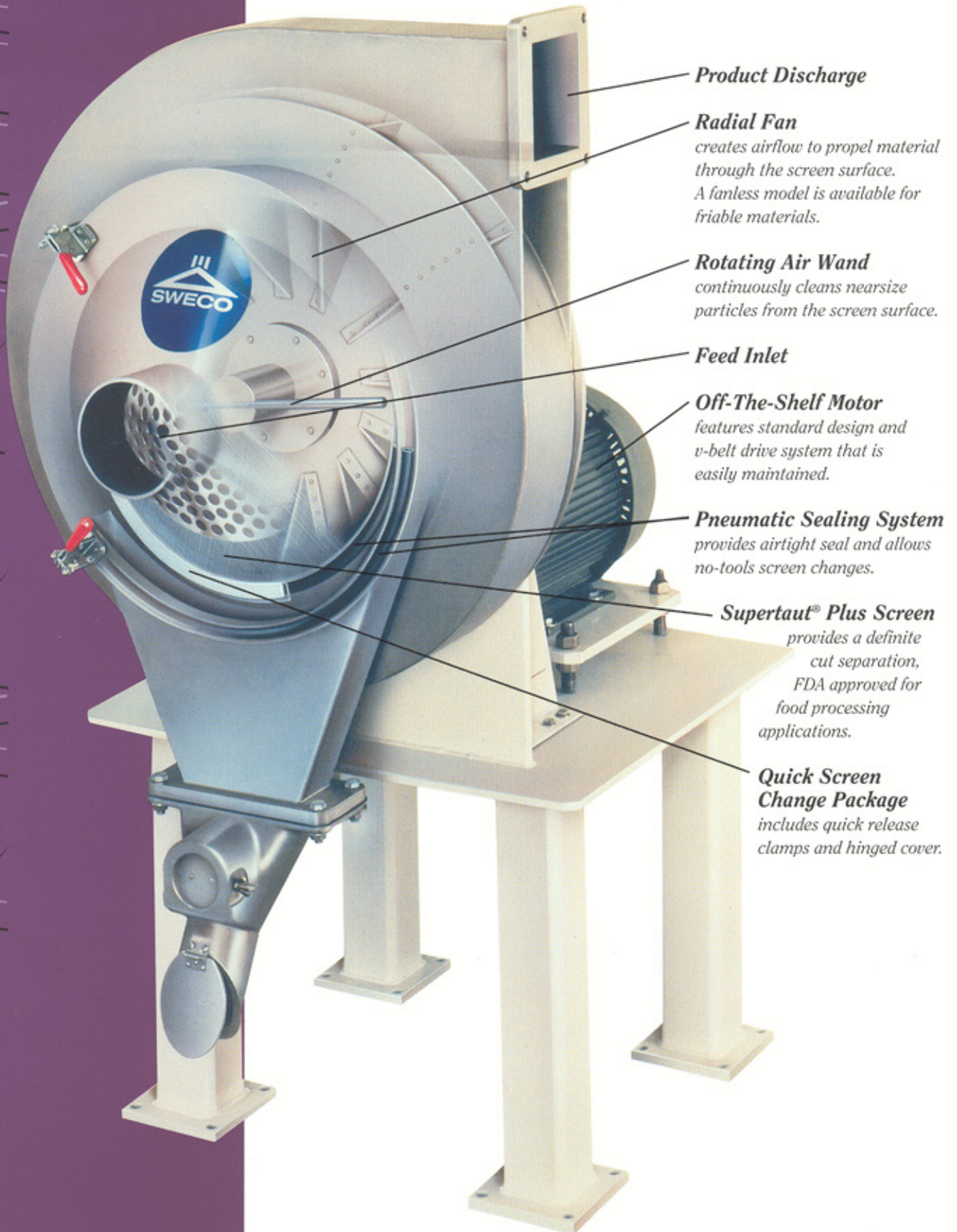

Product Discharge

Radial Fan

creates airflow to propel material through the screen surface. A fanless model is available for friable materials.

Rotating Air Wand

continuously cleans nearsize particles from the screen surface.

Feed Inlet

Off-The-Shelf Motor

features standard design and v-belt drive system that is easily maintained.

Pneumatic Sealing System

provides airtight seal and allows no-tools screen changes.

Supertaut® Plus Screen

provides a definite cut separation, FDA approved for food processing applications.

Quick Screen Change Package

includes quick release clamps and hinged cover.

OPERATION

Simple Operation-Superior Results

Downtime factors have been engineered out of the Turbo-Screen to allow continuous processing. An operator can change screens in just minutes without tools. Quick release clamps and a hinged cover allow easy access to the internal screen chamber. The material to be separated is continuously transported into the system and presented to the screen by

a high-velocity air flow, generated through a radial fan located in the housing behind the screen. Oversize particles are either collected or returned for further processing. The screened product is conveyed by the fan to a cyclone and/or dust collector and discharged. Blinding of the screen is prevented by a continuous blow-back system. A rotating air wand blows

a knife-edge sheet of compressed air against the back of the screen, to effectively prevent oversize and nearsize particles from blocking the screen openings.

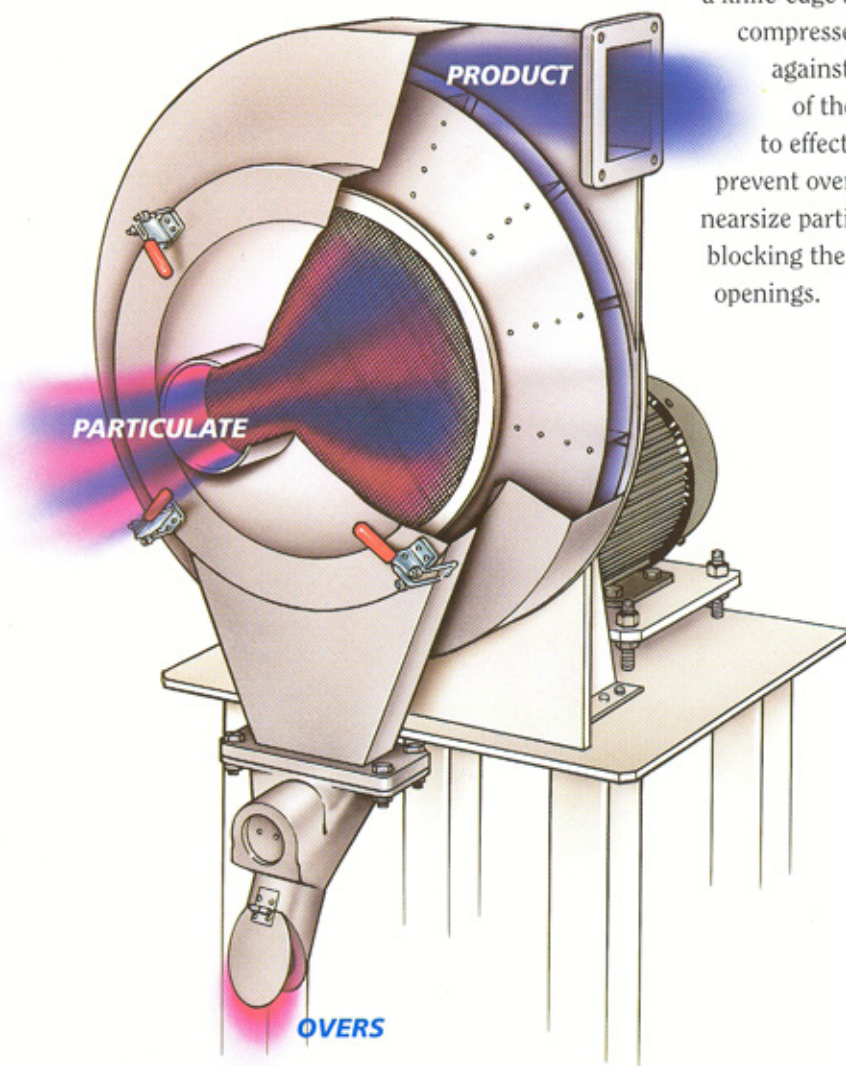

Whether your process requires precise screening of dry particles or high-volume solid/liquid separation, SWECO can provide quality equipment that is just right for the job. Innovative SWECO designs are backed by local representatives,

unparalleled technical support, and the broadest product line in the industry.

Visit our fully-staffed Technology Center and see for yourself how we are putting technology in motion for process plants all over the world.

The Clear Choice for Separation of Dry Particulate

The SWECO Turbo-Screen Air Classifier provides continuous, precise screening of dry materials, especially in the finer particle sizes. Designed to handle even the most difficult materials, the Turbo-Screen unit is ideally suited for separating electrostatic materials and particles that tend to agglomerate easily. In certain applications, it is the only machine capable of commercial scale separation.

The Turbo-Screen unit uses a variety of screen sizes, from 60 to 600 mesh, providing efficient separation of particles ranging from 25 to 300 microns. Unlike a standard air classifier, the Turbo-Screen system provides an absolute cut. This has opened new possibilities for fine-particle separation within a wide variety of industries, including food, chemical, powdered metal, plastic, electronic, and ceramic.

A Full Range Of Options And Accessories

Options available for the Turbo-Screen system, include:



- Adjust-a-Vibe™ Motion Controller for fine-tuning of process parameters.
- A variety of control panels are available to detect any inlet, screen, cyclone, or dust collector blockage.
- Feeding mechanisms for accurate material flow.
- Quick release cyclones (two-piece assembly) with a clamp ring for easy clean-out.
- Dust collector for dust-free operation.

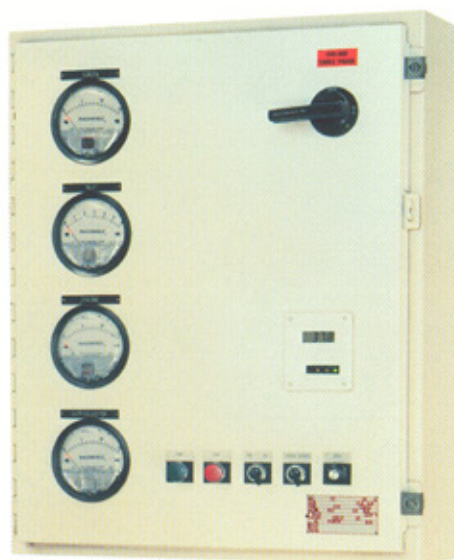

Deluxe Control Panel (optional)

displays relative pressures along the flow path.

Fanless Model Available

For materials which require very gentle handling, the Turbo-Screen is also available in a fanless version. The airflow in this model is created downstream of the cyclone by an external blower, eliminating contact between material and the fan. Operating characteristics are similar to the standard Turbo-Screen model.

Applications

SWECO Turbo-Screen Classifiers are currently processing a variety of material with bulk densities that range from 2 lbs./cubic foot (pollen particles) to over 400 lbs./cubic foot (metal powders). Our in-depth experience assures accurate processing of particles of all shapes and sizes. Typical applications include: Plastic Materials, Ceramic Powders, Metal Powders, Pharmaceuticals, Tobacco, Chemicals & Minerals, and Coal.

Total Systems Capability

Turbo-Screen Classifiers can be matched to other SWECO equipment in open or closed-circuit material handling systems. A grinding/separation system may include a SWECO Vibro-Energy Grinding Mill and a Turbo-Screen, skid-mounted to ease transportation and installation. In this type of arrangement, output from the Grinding Mill feeds the Turbo-Screen. Overs are sent back for regrind, while the fines fraction moves on for further processing. Approximate grinding chamber capacities of 3, 10, 20 and 70 cubic feet are available. SWECO can also provide upstream and downstream equipment to meet the requirements of almost any application.

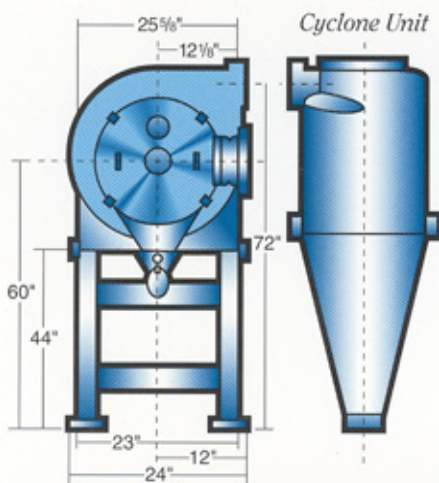
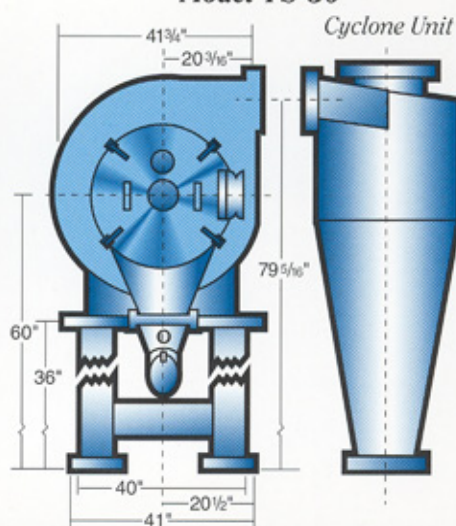
Model TS-18**Model TS-30****TURBO-SCREEN SPECIFICATIONS**

	Model TS-18	Model TS-30
Screen Diameter	18 inches	30 inches
Motor HP	5 HP	7.5 HP
Blower RPM	100-2200	100-1400
Air Volume at Maximum RPM	750 scfm	1500 scfm
Air Wand Pressure	30-75 psi	30-75 psi
Air Required to Operate Air Wand	15-35 scfm	30-70 scfm

MATERIALS OF CONSTRUCTION

Housing	Stainless Steel or Carbon Steel	Stainless Steel or Carbon Steel
Impeller	Stainless Steel	Stainless Steel
Air Wand	Stainless Steel	Stainless Steel
Stand	Carbon Steel	Carbon Steel
Cyclone	Stainless Steel	Stainless Steel or Carbon Steel
Shipping Weight (approx.)	480 lbs.	1080 lbs.



The full line of SWECO separation and grinding equipment can be tested, either in your plant or in our fully-staffed Technology Center.

SWECO, SWECO and logo, Turbo-Screen, Adjust-a-Vibe, and We Put Technology in Motion are trademarks and registered trademarks of M-I SWACO.

FEATURES

A Heritage of Screening Expertise

Each Turbo-Screen Classifier is backed by the strongest engineering and technical support staff in the industry. Testing is conducted in our fully-staffed Technology Center located in Florence, Kentucky. Your local representative can provide complete information on material requirements, scheduling, and fees. Armed with the broadest line of separation and particulate handling equipment, SWECO application engineers solve today's toughest separation problems, while our research and development team anticipates future demands.